

USB / Ethernet Production Ready Module

The USB / Ethernet module is a single board containing everything needed to add high-performance Internet and USB connectivity to customers' system designs without the need to understand the technology in detail.

CyanIDE™, the industry leading toolset with automatic peripheral configuration and gcc based C compiler allows easy customisation of the module and is free of charge. Software modules are provided through CyanIDE as easy-to-use templates. Many of the pins of the on-board eCOG1X 16-bit MCU are brought out to the pins of the module. Maximum flexibility in configuring the device on-chip peripherals is available to the designer through the CyanIDE configurator tool.

Typical application areas include industrial communications, for example a web server link to sensors; serial to USB or Ethernet conversion; Ethernet connection to USB hosted peripherals. Typical markets are utility metering, vending / gaming machines, security systems, and control and monitoring systems. Products requiring large quantities of Flash memory and high performance analogue to digital or digital to analogue conversion are particularly well served.

Module Key Features:

- ◆ Small size - 60mm x 57mm
- ◆ eCOG1X14Z5 microcontroller
- ◆ Two 2x20 2mm pitch pin headers bring out many MCU pins for customer use
 - ◆ 8 MCU analogue inputs
 - ◆ 2 MCU analogue outputs
 - ◆ 52 MCU digital I/O
- ◆ 16MB external SDRAM
- ◆ SD / MMC socket
- ◆ 10/100Base-T Ethernet PHY and RJ45 connector
- ◆ Preprogrammed MAC address and serial no.
- ◆ USB 2.0 Full-Speed interface - host (A socket) and peripheral (B socket) versions
- ◆ Separate USB VBus pin
- ◆ Connectors arranged for easy panel mounting
- ◆ Development base board available, providing power and debug
- ◆ Operating temperature range: 0°C to +70°C
- ◆ Single 3.3V supply

MCU Features include:

- ◆ 72MHz eCOG1X14Z5
- ◆ 512KB Flash / 24KB RAM
- ◆ 10/100 Ethernet MAC
- ◆ USB 2.0 controller
- ◆ 5 multi-purpose timers
- ◆ Code security feature
- ◆ Accessible on module pins:
 - ◆ 12-bit ADC (8 inputs)
 - ◆ 12-bit DAC (2 outputs)
 - ◆ Parallel I/O port
 - ◆ UART, I2C & SPI serial interfaces
 - ◆ 6 x PWM timers for motor control
 - ◆ Capture timer with 6 inputs

Software included with CyanIDE:

- ◆ GNU C compiler / debugger
- ◆ Eclipse IDE
- ◆ Open source TCP/IP stack with support for HTTP, FTP, SMTP, Telnet, DHCP, TFTP, BOOTP, SNTP & SNMP
- ◆ FAT16 / FAT32 filing system
- ◆ SD / MMC low-level device interface
- ◆ USB CDC*, HID and MSD (mass-storage) device classes

* Restrictions apply according to version of MS Windows®

Block diagram

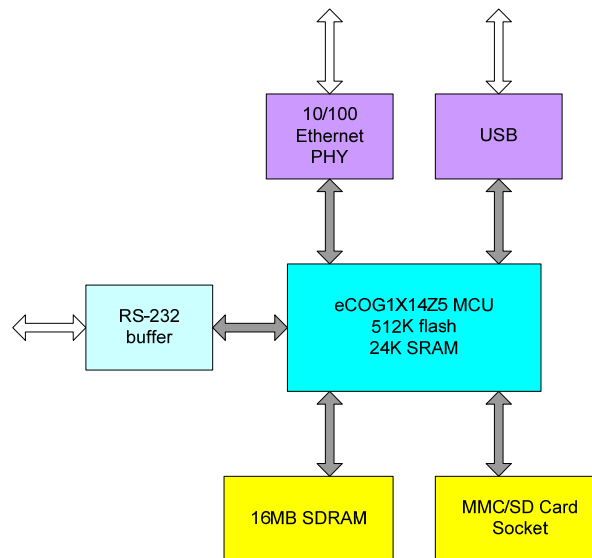

Hardware Description

Microcontroller

The module uses a Cyan eCOG1X14Z5 microcontroller as the processor. This device has a CPU core that operates at an internal clock frequency of up to 72 MHz, 512Kbytes of flash memory and 24Kbytes of SRAM. It also has a wide range of peripheral functions, including the Ethernet and USB interfaces used here.

Software development is performed using the CyanIDE environment. It includes a full C compiler (gcc), source level debugger (gdb), Eclipse based IDE, and supports a direct debug connection to the target processor through a dedicated serial interface (eICE).

Memory

In addition to the memory within the eCOG1X MCU device, the module includes an additional 16 Mbytes of on-board SDRAM and a standard card socket for an SD or MMC memory card. The SDRAM is connected directly to the eCOG1X external memory interface bus. Software support for the SD card includes both a low level device driver and a library that implements an industry standard FAT file system.

USB

The eCOG1X MCU includes a USB peripheral with an on-chip PHY, supporting low speed (1.5 Mb/s) and full speed (12 Mb/s) operation. Several standard USB host and peripheral functions are supported with a comprehensive software library. Example projects for a range of applications are included with CyanIDE as standard.

The module is available with either a B-type USB connector, suitable for USB peripheral applications or an A-type, suitable for USB host.

10/100 Mb/s Ethernet

The eCOG1X includes an on-chip 10/100 Ethernet MAC. An external Micrel KSZ8041 device provides a twisted-pair PHY, connected via a standard RJ45 connector.

Other Information

- Power supply: 5V +/-10% @ TBD mA.
- Operating temperature range: 0°C to +70°C
- Board size: 60 mm x 57 mm

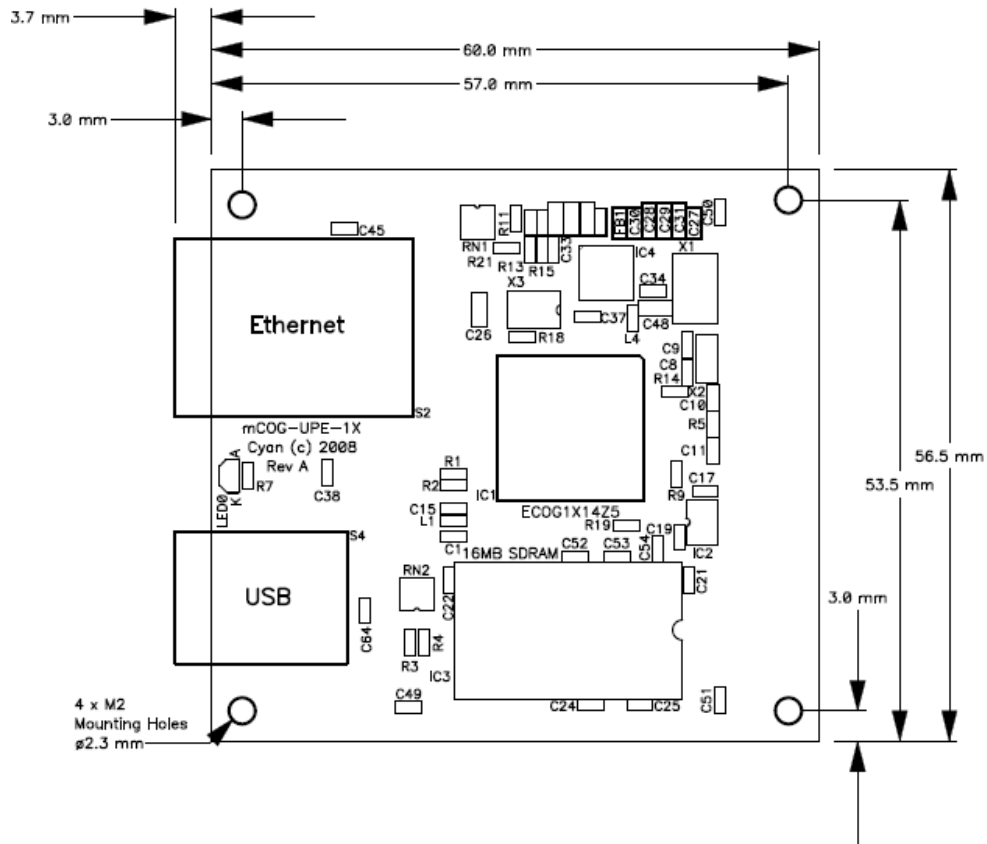

Module outline and mechanical dimensions – top view

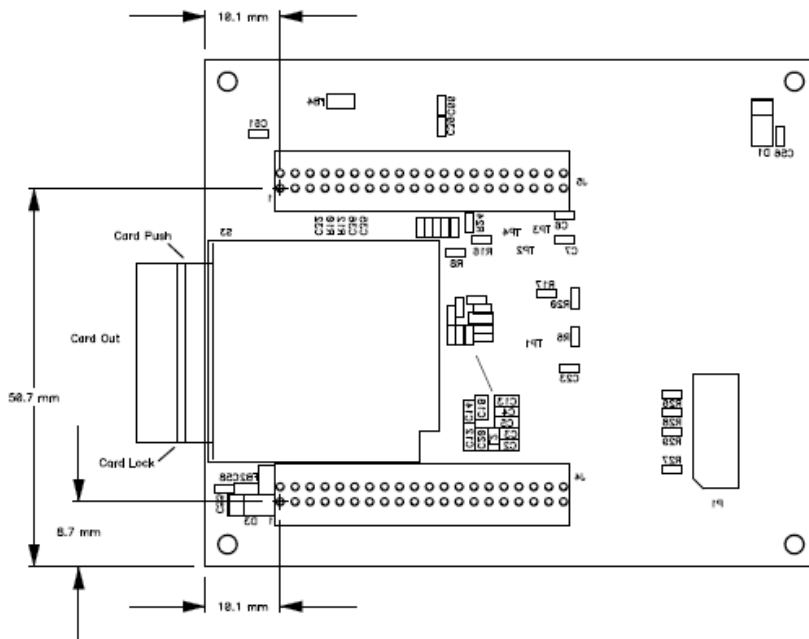

Module connector locations – bottom view

Application Software

A comprehensive set of application and support software is provided with the module and the CyanIDE development environment.

Cyan Driver Framework (CYDF)

The CYDF Cyan Driver Framework is a set of device drivers and APIs that supports a wide range of peripheral functions, including the serial port connection to the module.

USB Library and Plug-Ins

CyanIDE includes an extensive USB support library for the eCOG1X. It includes a number of software “plugins” that can be added to applications to support common USB peripheral functions.

The USB support library offers the following features:

- Configuration and setup is done within CyanIDE.
- USB host, peripheral and On-The-Go operation.
- Low speed and full speed transfers.
- Event driven messaging model, with event queue.
- Low level access to USB core hardware, if required.
- Integration with eCOG1X DMA peripheral for memory transfers.
- Plugins for common USB applications, requiring only minor custom configuration.
- Low memory usage.

FAT File System

The FAT file system library provides a number of disk, file and directory manipulation routines for FAT16 and FAT32 disk formats. These disk formats are the most commonly used formats for solid-state memory cards that are used with digital cameras, MP3 players and other portable devices.

The library only requires simple block read and write access routines, allowing it to be used on top of lower level disk access routines; for example direct access to SD flash memory cards.

The FAT library offers the following features:

- FAT16 and FAT32 support
- Read and write accesses
- Supports multiple partitions on a disk
- Supports nested subdirectories
- C-library style routines
(`fopen()`, `fread()`, `fwrite()`, `fclose()`, `ftell()`, `fseek()`)
- Fast file block read and write routines
- File and directory delete
- Multiple open files at the same time
- Low level disk access routines
- Quick and full format
- Create and delete partitions
- Low RAM requirement (less than 1KB)
- Low program memory requirement

Ethernet TCP/IP Stack

The software provided with the module includes source code and project templates based on the open-source uIP TCP/IP network stack.

The uIP package provides an implementation of the TCP/IP protocol stack for embedded microcontrollers, without sacrificing interoperability or RFC standards compliance. It provides the necessary protocols for Internet communication, with very small code and data memory requirements. Cyan's port of uIP includes a number of application examples using a range of standard protocols and services. Additional services, protocols and application layer components may be available in future.

uIP is developed by Adam Dunkels at the Swedish Institute of Computer Science. For more information about uIP, please visit the uIP web site at <http://www.sics.se/~adam/uip/>. The uIP reference manual is available at <http://www.sics.se/~adam/download/uip-1.0-refman.pdf>.

PC-Based Application

The quick start guide includes demonstrations of some of the USB and Ethernet applications possible with the module. The below example shows the use of the module to view and control an embedded system from a standard web browser, via an HTTP server using an additional store for the various pages to be displayed. These page data files are stored on an SDcard or a USB memory stick, (USB host variant of the module only) and are used to view network and file statistics.

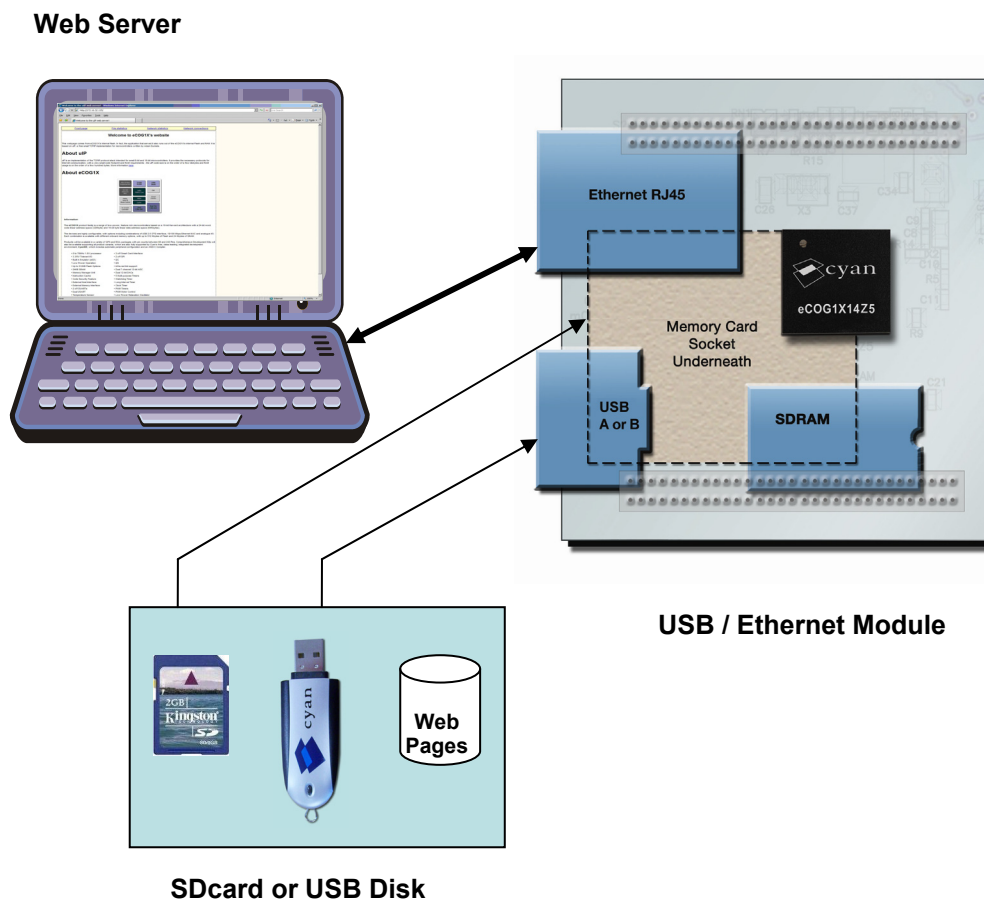

Demo system configuration

Module Connections

The module has the following signals available on two 2x20-way 2mm pitch daughter board connectors, J4 and J5.

J4	Pin	Name	Function	Pin	Name	Function
	1	Vbus	+5V supply from USB	2	GND	
	3	PortS_0	GPIO/UART/PWM [*]	4	PortS_1	GPIO/UART/PWM [*]
	5	PortS_2	GPIO/UART/PWM [*]	6	PortS_3	GPIO/UART/PWM [*]
	7	PortS_4	GPIO/UART/PWM [*]	8	PortS_5	GPIO/UART/PWM [*]
	9	PortS_6	GPIO/UART/PWM [*]	10	PortS_7	GPIO/UART/PWM [*]
	11	PortM_0	GPIO/LCD/PIO/SmartCard [*]	12	PortM_1	GPIO/LCD/PIO/SmartCard [*]
	13	PortM_2	GPIO/LCD/PIO/SmartCard [*]	14	PortM_3	GPIO/LCD/PIO/SmartCard [*]
	15	PortM_4	GPIO/LCD/PIO/SmartCard [*]	16	PortM_5	GPIO/LCD/PIO [*]
	17	PortM_6	GPIO/LCD/PIO [*]	18	PortM_7	GPIO/LCD/PIO [*]
	19	PortN_0	GPIO/LCD/PIO/SmartCard [*]	20	PortN_1	GPIO/LCD/PIO/SmartCard [*]
	21	PortN_2	GPIO/LCD/PIO/SmartCard [*]	22	PortN_3	GPIO/LCD/PIO/SmartCard [*]
	23	PortN_4	GPIO/LCD/PIO/SmartCard [*]	24	PortN_5	GPIO/LCD/PIO/SmartCard [*]
	25	PortN_6	GPIO/LCD/PIO [*]	26	PortN_7	GPIO/LCD/PIO [*]
	27	DAC1	Analogue output	28	DAC2	Analogue output
	29	+3.3V	VDD power supply	30	GND	
	31	ADC4	Analogue input	32	ADC8	Analogue input
	33	ADC3	Analogue input	34	ADC7	Analogue input
	35	ADC2	Analogue input	36	ADC6	Analogue input
	37	ADC1	Analogue input	38	ADC5	Analogue input
	39	+3.3V	VDD power supply	40	GND	
J5	Pin	Name	Function	Pin	Name	Function
	1	+3.3V	VDD power supply	2	CHASSIS	
	3	NC		4	GND	
	5	PortC_0	GPIO/CAP/CNT/I2C/IR [*]	6	PortC_1	GPIO/CAP/CNT/I2C/IR [*]
	7	PortC_2	GPIO/CAP/CNT/IR [*]	8	PortC_3	GPIO/CAP/CNT/IR [*]
	9	PortR_0	GPIO/CAP/PWM [*]	10	PortR_1	GPIO/CAP/PWM [*]
	11	PortR_2	GPIO/CAP/PWM [*]	12	PortR_3	GPIO/CAP/PWM [*]
	13	PortR_4	GPIO/CAP/PWM [*]	14	PortR_5	GPIO/CAP/PWM [*]
	15	PortR_6	GPIO/CAP/PWM [*]	16	PortR_7	GPIO/CAP/PWM [*]
	17	eICE_LOADB	DEBUG	18	eICE_MOSI	DEBUG
	19	eICE_MISO	DEBUG	20	eICE_CLOCK	DEBUG
	21	nReset_Out	DEBUG	22	nReset_In	DEBUG
	23	PortL_0	GPIO/UART/I2C/IR [*]	24	PortL_1	GPIO/UART/I2C/IR [*]
	25	PortL_2	GPIO/UART/IR [*]	26	PortL_3	GPIO/UART/IR [*]
	27	PortP_0	GPIO/PIO/LCD [*]	28	PortP_1	GPIO/PIO/LCD [*]
	29	PortP_2	GPIO/PIO/LCD [*]	30	PortP_3	GPIO/PIO/LCD [*]
	31	PortP_4	GPIO/PIO/LCD [*]	32	PortP_5	GPIO/PIO/LCD [*]
	33	PortP_6	GPIO/PIO/LCD [*]	34	PortP_7	GPIO/PIO/LCD [*]
	35	PortK_0	GPIO/LCD/I2C/IR [*]	36	PortK_1	GPIO/LCD/I2C/IR [*]
	37	PortK_2	GPIO/LCD/IR [*]	38	PortK_3	GPIO/LCD/IR [*]
	39	+3.3V	VDD power supply	40	GND	

J4 & J5: Module connections

All GPIO pins are configurable as various peripheral pins. The table shows a small subset of the functionality of each. Refer to the eCOG1X User Manual for a comprehensive list of peripheral options.

Ordering Information

Modules

Part Number	USB	SDRAM	SD/MMC Card
mCOG-UPE-1X-DM1	Socket B (peripheral)	16MB	Yes
mCOG-UHE-1X-DM1	Socket A (host)	16MB	Yes

Evaluation Kits

Part Number	Kit contents
EVALKIT-UPE-1X	Peripheral module + base board + CyanIDE CD + eICE dongle + cables
EVALKIT-UHE-1X	Host module + base board + CyanIDE CD + eICE dongle + cables

Notes

Cyan Technology Limited recognises all brand and product names used in this document as trademarks or registered trademarks of their respective owners.

This product is not designed or intended to be used for on-line control of aircraft, aircraft navigation or communications systems or in air traffic control applications or in the design, construction, operation or maintenance of any nuclear facility, or for any medical use related to life support equipment or systems intended to be surgically implanted into the body or any other life-critical application, whose failure to perform per documented instructions, can be reasonably expected to cause loss of life or significant injury. Cyan specifically disclaims any express or implied warranty of fitness for any or all of such uses.

Declaration of RoHS Compliance

Cyan Technology Ltd hereby declares that the USB / Ethernet module is in full compliance with the European Directive 2002/95/EC, The Restriction of Hazardous Substances in Electrical and Electronic Equipment (RoHS).

This declaration is made based on data provided by our material suppliers, and independent analysis of all homogenous materials used in the manufacture of the product.

Cyan Technology Ltd is a wholly owned subsidiary of Cyan Holdings plc

Cyan Technology Ltd
Buckingway Business Park
Swavesey
Cambridge
CB24 4UQ

Tel: +44 (0)1954 234400
Fax: +44 (0)1954 234405
www.cyantechnology.com

V1.0 08 December 2008